

Stepper Motors

Two phases, 24 steps per revolution



For combination with:
Encoders: AE 23B8, IE2
Drive Electronics: AD VL M, AD VM M, AD CM M

Series AM 2224 – R3

	AV - 4,8		AV - 18		V - 12		V - 24	
	Current mode	Voltage mode	Current mode	Voltage mode	Voltage mode			
1 Nominal voltage U_N	6 ... 30	3	6 ... 30	6	12	24	V DC	
2 Phase resistance (at 20°C)	4,8	4,8	18	18	75	290	Ω	
3 Phase inductance (1kHz)	8,5	8,5	35	35	135	620	mH	
4 Nominal current per phase (both phases ON)	0,50	0,60	0,25	0,33	0,16	0,09	A	
5 Back-EMF amplitude	8,3	8,3	16,7	16,7	33,0	67	V/k step/s	
6 Holding torque ¹⁾ (at nominal current in both phases)	26							
7 Holding torque ¹⁾ (at twice the nominal current)	45							
8 Residual and friction torque	2							
9 Thermal resistance winding-ambient air	28							
10 Winding temperature tolerated, max.	130							
11 Ambient temperature range	-40 ... +70							
12 Thermal time constant	600							
13 Step angle (full step)	15							
14 Angular accuracy ²⁾	± 5							
15 Rotor inertia	228							
16 Shaft bearings	ball bearings, preloaded							
17 Shaft load, max.:								
– radial (3 mm from bearing)	20,0							
– axial	3,0							
18 Shaft play, max.:								
– radial (1N)	15							
– axial (1N)	~0							
19 Weight	43							
20 Isolation test voltage	200							
21 Resonance frequency	100							
22 Electrical time constant	1,7							

¹⁾ with bipolar driver

²⁾ 2 phases ON, balanced phase current

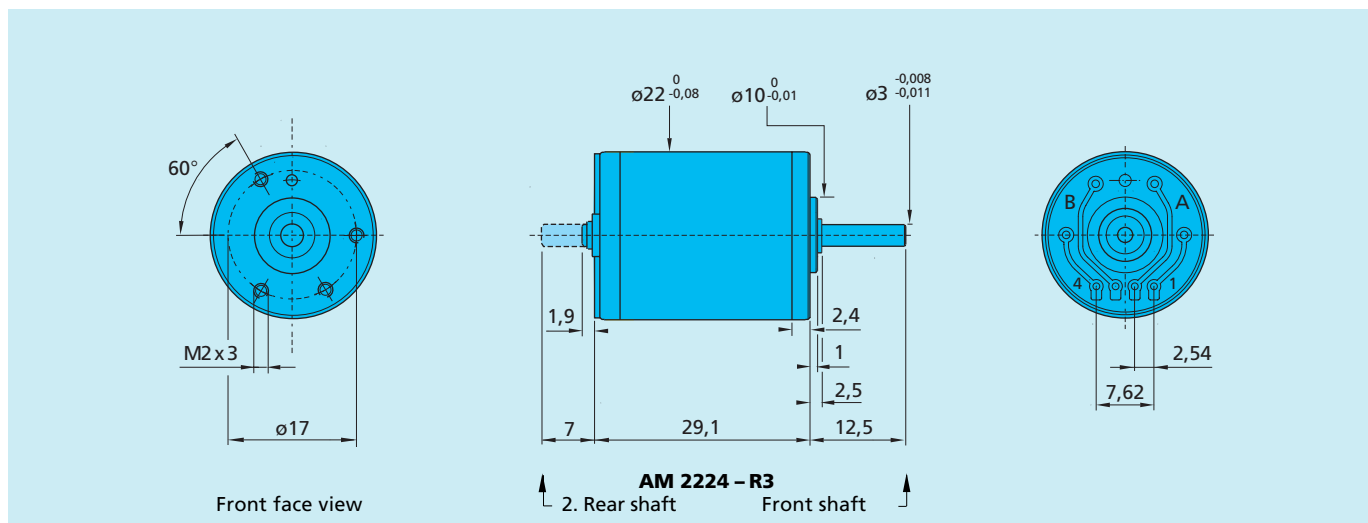
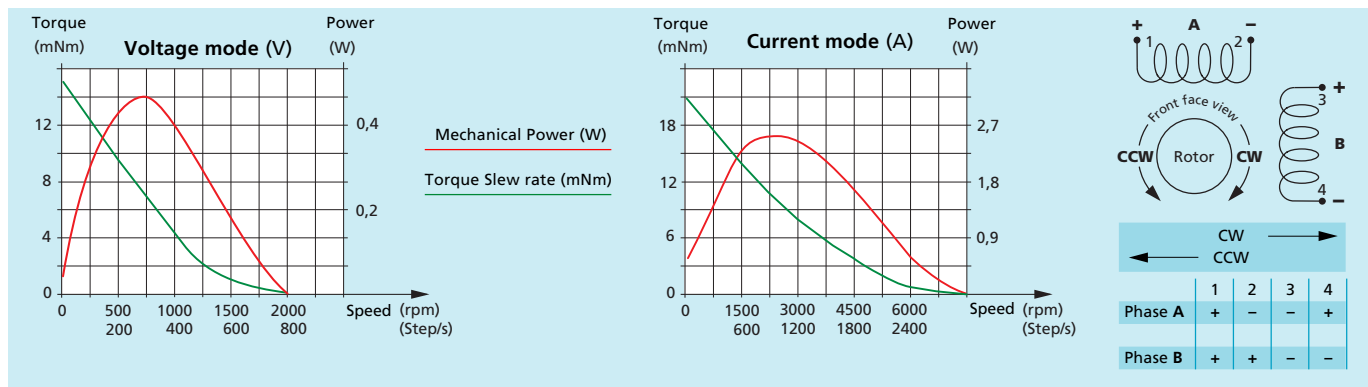

For notes on technical data refer to „Technical Information“

Specifications subject to change without notice

Edition 03.02.2003