

COPAL ELECTRONICS

Electronic pressure switch

PS91

CE marking
(Compliance with EMC Standard)

Instruction manual Ver.1.2

Thank you for purchasing NIDEC COPAL ELECTRONICS CORP. product.

In order to use the product correctly and most appropriately, please read this manual before use and keep it for future reference. If you have any questions or concerns, please feel free to contact us.

For more detailed information please ask for the nearest distributor or the following sales center.

COPAL ELECTRONICS

Nishi-Shinjuku Kimuraya Bldg., 7-5-25
Nishi-Shinjuku Shinjuku-ku Tokyo 160-0023, Japan Phone.:(03) 3364-7055

Safety instructions

Please read these safety instructions prior to using this product. The following safety concern is for avoiding any miss-use and to prevent any harms or casualties.

⚠ Caution : This caution mark describes when there is possibility that user may suffer from damage or physical damage may occur if the product is used improperly.

⚠ Caution

Piping

K 2 type : Please install the clamp fittings properly.

V C type : Install the product properly by using a wrench to the hexagonal portion of the sensor.

Do not apply any unnecessary force to the cable when installing.

Please check the piping for any leakage after the sensor is installed.

Wiring

Please wire accordingly to the chart below.

Please be careful not to miss-wire.

Wire color	Connection
Red	Power (+)
Black	Common
Green	Switch output 1
White	Switch output 2
Shield	

Never make any short-circuits; it may result in an internal circuit damage.

The shield wire is connected to the inside part of the fitting. If the sensor is earthed through the piping, do not earth the shield wire. If the sensor is not earthed through the piping, please earth the shield wire. If a wire extension is needed, please use a shielded wire.

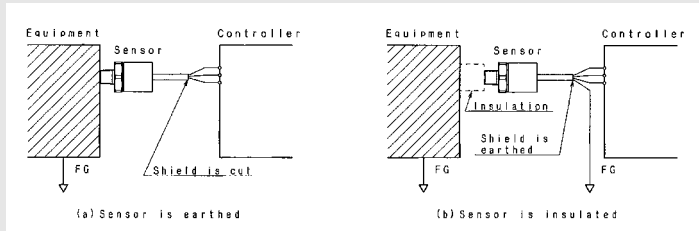

Handling

- (1) Pressure port material is made of SUS316L
- (2) This product can be used for corrosive and non-corrosive gases / liquids compatible with SUS316L.
- (3) Other than specified pressure media, never insert any foreign matter into the pressure port (ex. Needle) It may result in malfunction.
- (4) Do not apply pressure exceeding the maximum pressure. (Twice the rated pressure)
- (5) Never connect the switch output(s) to load over 100mA. It may result in malfunction.
- (6) Use a regulated direct current power supply for stability. Surge absorbing devices (diodes, varistors, etc.) are necessary if inductive loads such as relays or solenoids are connected to power line and / or to the switch output(s)
The FG terminal on the unit power supply should be earthed. (Refer to the diagrams below)
- (7) For flange fitting (K2 type), do not scratch the sealing surface.
- (8) For gasket fitting (VC type), since the edge of the fitting is mirror polished, do not scratch the edge of the fitting.
- (9) This product is not waterproofed. Do not use this product in environment with a chance of water splash.

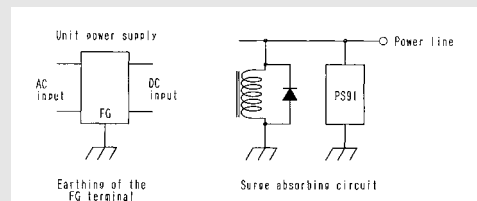

1. Part number designation

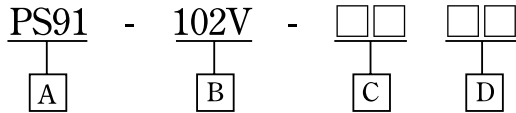

Part number designation

A : Part name

B : Rated pressure 102V:-100~10kPa

C : Switch configuration

N 1 : N P N (Upper, Upper limit) P 1 : P N P (Upper, Upper limit)

N 2 : N P N (Upper, Lower limit) P 2 : P N P (Upper, Lower limit)

D : Fitting

K 2 : Flange fitting (NW25)

V C : Gasket fitting (9/16-18UNF)

●Please refer to "5.4 Switch output operation" for more details.

2. Setting method of switching pressure

①For adjusting switch output 1, apply pressure up to the point where switch operation is needed. Then slowly turn the trimmer (On the left side of VR) to the left until the LED 1 turns on.

②For adjusting switch output 2, apply pressure up to the point where switch operation is needed. Then slowly turn the trimmer (On the right side of VR) to the left until the LED 2 turns on.

●By turning the trimmer clock-wise, the setting value will increase towards vacuum.

3. Internal circuit

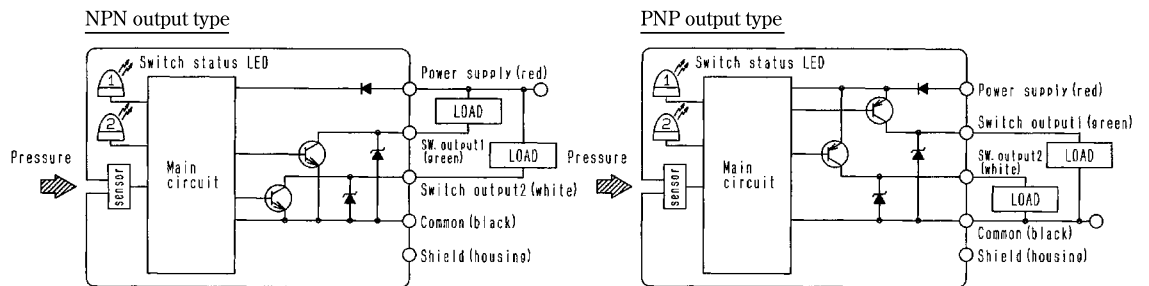

4. Outline dimensions

(1) K 2 type

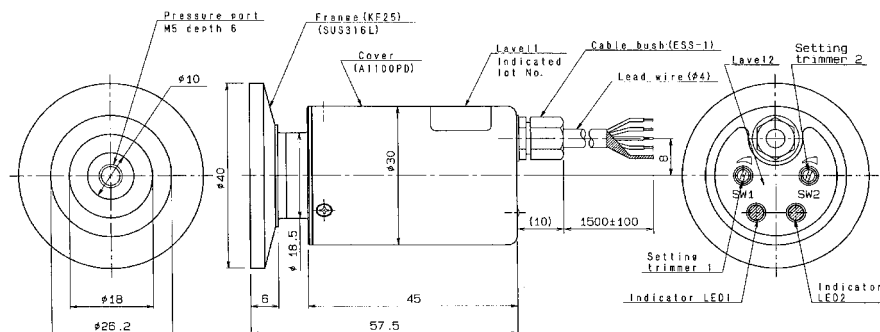

(2) V C type

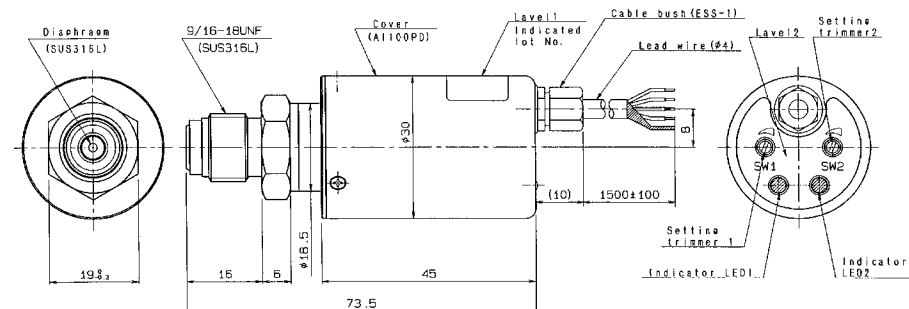

5. Specification

5.1 General specifications

Item	Specification
Maximum pressure	200kPa
Break-down pressure	300kPa
Operating temp. range	-20°C ~ 80°C
Compensated temp. range	0°C ~ 50°C
Operating humidity	35 ~ 85%RH
Storage temp. range	-20°C ~ 80°C
Media	Gases / liquids compatible with SUS316L
Weight	Approx. 140g

5.2 Power

Item	Specification
Operating voltage	12 ~ 24VDC ± 10%
Current consumption	15mA max. (No load, switch ON)

5.3 Switch Output

Item	Specification
Number of outputs	2
Output interface	NPN or PNP open collector type
Setting method	Adjustable by trimmer
Switch setting range	-100kPa ~ 10kPa
Switching mode	Upper, upper limit / Upper, lower limit
Output display	Red LED light (Switch 1 Switch 2)
Accuracy	±3% F.S
Hysteresis	2% F.S Max.
Switching capacity	30VDC 100mA Max.
Residual voltage	NPN: 0.8V Max. / PNP: 1.6V Max.

5.4 Switch output operation

N1 / P1 type

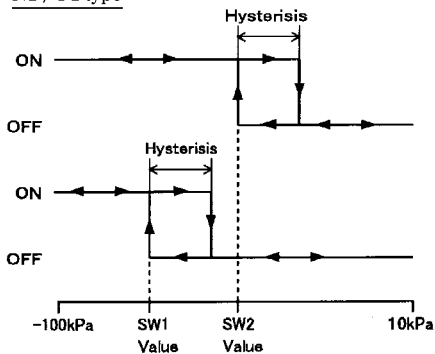

N2 / P2 type

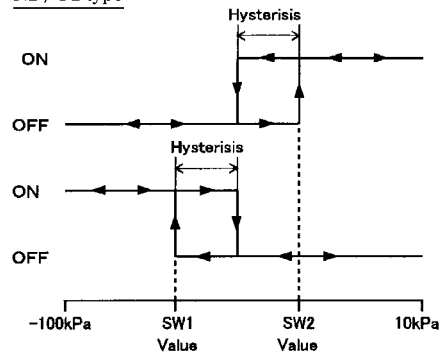

6. Warranty

This product is covered by warranty for a period of one year from the date of delivery.

This warranty is only applicable to this product itself.

This warranty covers free-of-charge repair and replacement for defects occurring through design or manufacturing inadequacy of NIDEC COPAL ELECTRONICS CORP. Even during the warranty period, the following failures will be handled on a fee basis.

- 1) Failure or damages occurring through misuse or disoperation performed not following the instruction manual, the catalog and the specification sheet.
- 2) Failure or damages occurring through improper modification, adjustment, or repair.
- 3) Failure or damages occurring through technically and scientifically unpredictable factors.
- 4) Failure or damages occurring through natural calamities, fires or other inevitable accidents.