

PS30

PRESSURE SWITCHES WITH GAUGE

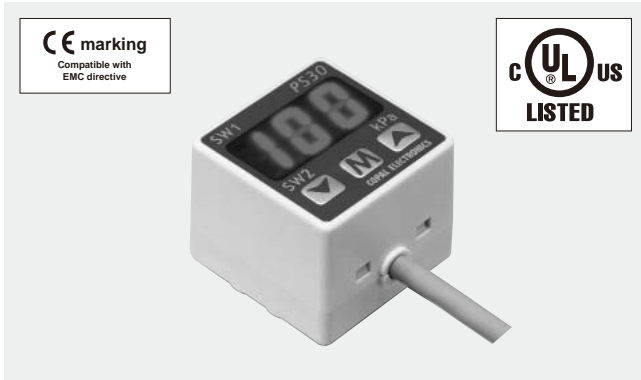

INTERNAL STRUCTURE

Part name	Material
① Pressure transducer	P-2000
② "O" ring	Fluoro-rubber
③ Pressure port	Brass (Ni-plated)
④ Base	ABS (Acrylonitrile-butadiene-styrene)
⑤ Housing	
⑥ Panel sheet	Polyester

FEATURES

- Optimum for pneumatic equipment and semiconductor manufacturing equipment
- Larger size display and high luminance LED for best visibility
- Eight switch output modes
- Low consumption by nondisplay mode

MODEL NUMBER DESIGNATION

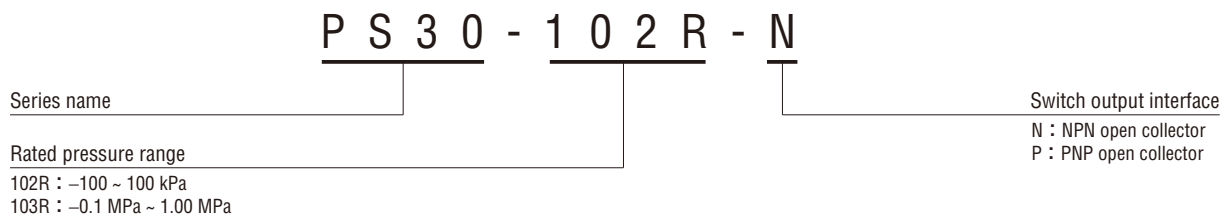

LIST OF MODEL NUMBERS

Switch output interface	Pressure reference	Gauge	
	Rated pressure range	-100 ~ 100 kPa	-100 ~ 1000 kPa
NPN		PS30-102R-N	PS30-103R-N
PNP		PS30-102R-P	PS30-103R-P

※ Please refer to the LIST OF MODEL NUMBERS when placing orders.

PS30
PRESSURE SWITCHES WITH GAUGE

STANDARD SPECIFICATIONS

● Unless otherwise specified, the specs are defined at an ambient temperature of 25 ± 5 °C and excitation voltage of 24 V DC.

Item		Model number	PS30	
			102R	103R
General specifications	Pressure reference		Gauge	
	Rated pressure range	kPa	-100 ~ 100	-100 ~ 1000
	Maximum pressure	kPa	200	1500
	Break-down pressure	kPa	500	2000
	Operating temp. range	°C	-10 ~ 50	
	Compensated temp. range	°C	0 ~ 50	
	Thermal error		±3 %F.S. (0 ~ 50 °C)	
	Operating humidity	%RH	35 ~ 85 (No condensation)	
	Storage temp.	°C	-20 ~ 70 (Atmospheric pressure, humidity 65 %RH maximum)	
	Pressure medium		Non-corrosive gases	
	Insulation resistance	MΩminimum	100 (DC500 V)	
	Dielectric strength		500 V AC, 60 s (Leakage current 1 mA maximum)	
	Pressure port		M5 female screw, "O" ring groove (P8)	
	Net weight	g	Approx. 60 (Including 1.5 m cable)	
Power	Supply voltage	V DC	12 ~ 24 V ± 10 % (Including ripple voltage)	
	Consumption current	mA maximum	40	
Display	Display element		LED (2 and 1/2 digit)	
	Rated display range	kPa	-100 ~ 100	_____
		MPa	_____	-0.10 ~ 1.00
	Display accuracy		±1 %F.S.	
Resolution		1 count		
Switch output	No. of outputs		2	
	Output interface		Open collector output (NPN or PNP)	
	Display		Output 1 (SW1), Output 2 (SW2) Light on when output is ON.	
	Repeatability	%F.S.	±0.3 maximum	
	Switch hysteresis		0 ~ 30 counts (Adjustable)	
	Switching capacity		30 V DC 100 mA maximum Short-circuit protection	
	Residual voltage	V maximum	1.2 V (NPN), 2.2 V (PNP)	
	Response	ms	Approx 5, 25, 250 (Adjustable)	

ENVIRONMENTAL CHARACTERISTICS

Test item	Test conditions	Permissible change
Vibration	10~500 Hz, 98.1 m/s ² or 1.5 mm P-P, 3 directions for 2 hours each	± 2 %F.S. maximum after test ※ 1
Shock	490 m/s ² , 3 directions for 3 times each	
Pressure cycling	0 ~ Rated pressure、10 ⁶ cycles	
Moisture resistance	40 °C, 90 ~ 95 %RH, 240 hrs.	
EMC	EMI : EN 55011 Group 1, class B (1991) EMS : EN 61326-1	± 5 %F.S. maximum during test ※ 1

※ 1 Change in the pressure indication, switch operating points.

PS30 PRESSURE SWITCHES WITH GAUGE

OUTLINE DIMENSIONS

Unless otherwise specified, tolerance : ± 0.5 (Unit : mm)

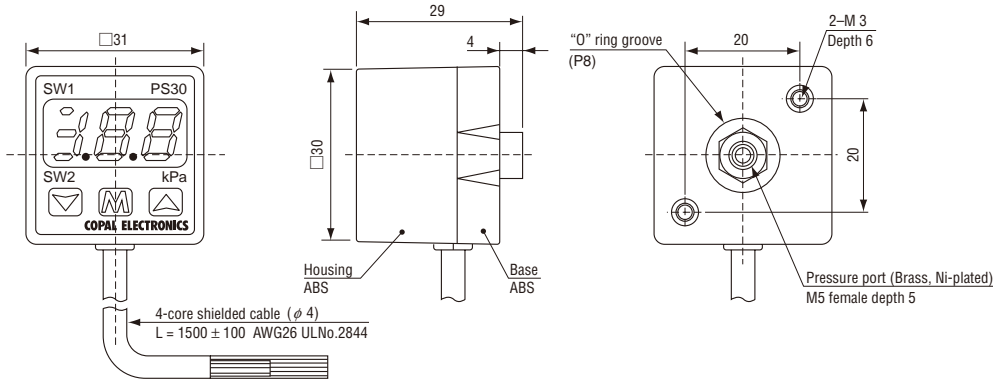

PS30

Wire color	Connection
Brown	Power ⊕
Black	Switch output 1
White	Switch output 2
Blue	Common

INTERNAL ELECTRICAL SCHEMATICS

● NPN

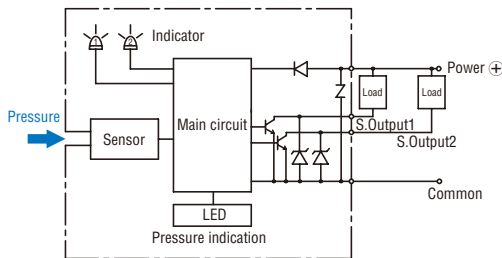

● PNP

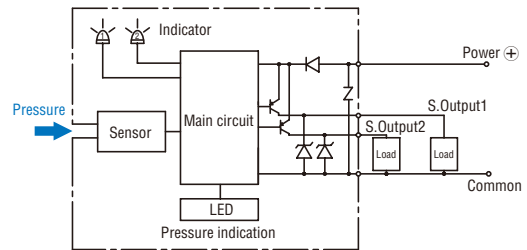

PRESSURE UNIT SETTING

Please refer to the right list.

(Note) Diagonal column : No unit can be selected due to resolution and number of digits.

Selection number	Pressure unit	Pressure range			
		102R		103R	
		Display multiplier	Display range	Display multiplier	Display range
0	kPa	×1	-100 ~ 100	/	/
1	MPa	/	/	×1	-0.10 ~ 1.00
2	cmHg	×0.75	-75 ~ 75	/	/
3	bar	×0.01	-1.00 ~ 1.00	×10	-1.0 ~ 10.0
4	psi	×0.145	-14.5 ~ 14.5	×145	-14 ~ 145

SWITCH OUTPUT MODE

Output	SW 1				SW 2			
	Separate		Window comparator		Separate		Window comparator	
	HI	LO	A	B	HI	LO	A	B
Selection number	0	○			○			
	1	○				○		
	2		○		○			
	3		○			○		
	4			○			○	
	5			○				○
	6				○			○
	7				○			○
Setting 1 Note 1		Lower limit : Setting 1 Upper limit : Setting 1 Note 2		Setting 1 Note 1		Lower limit : Setting 1 Upper limit : Setting 1 Note 2		

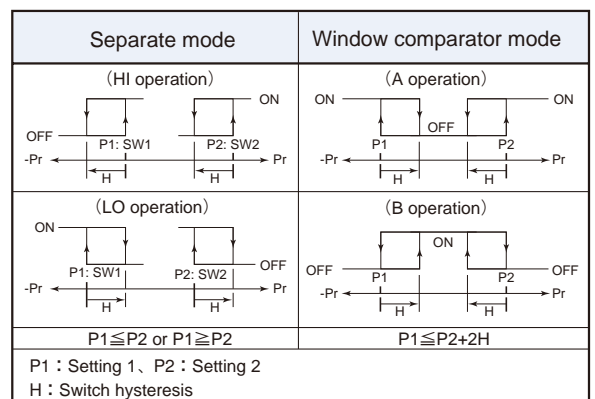

(Note 1) In the Separate Mode, setting 1 corresponds to SW1, and Setting 2 corresponds to SW2.

(Note 2) In the Window Comparator Mode, the minimum value for SW1 and SW2 corresponds to Setting 1 and the maximum value corresponds to Setting 2.

PS30 PRESSURE SWITCHES WITH GAUGE

HOW TO MOUNT OPTIONAL ACCESSORIES (Sold separately)

● Port block

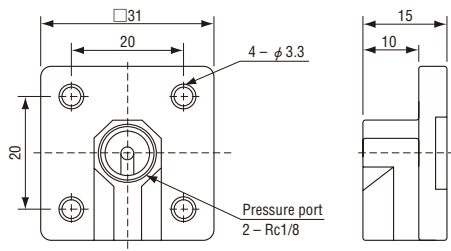

Material : Zink die-casting / nickel plate

● How to mount port block

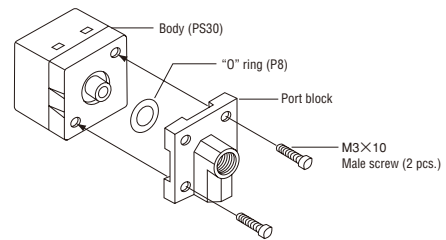

● Rear panel mounting bracket

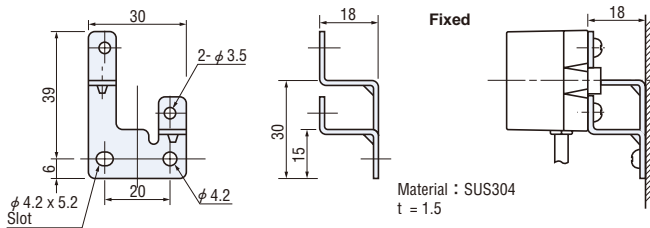

Material : SUS304
t = 1.5

● Panel mounting bracket

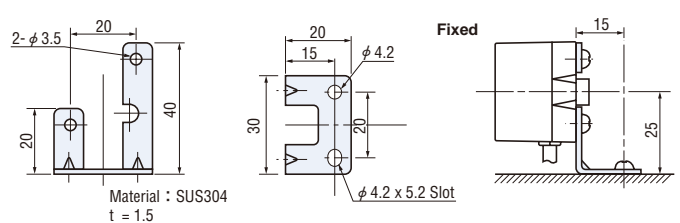

Material : SUS304
t = 1.5

● Panel mounting bracket (Option)

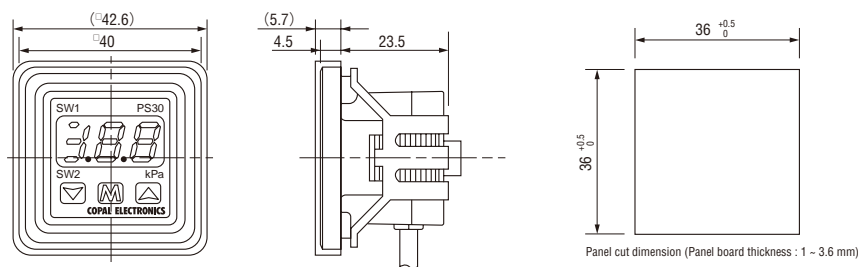

Panel cut dimension (Panel board thickness : 1 - 3.6 mm)

● How to mount panel holder cover set

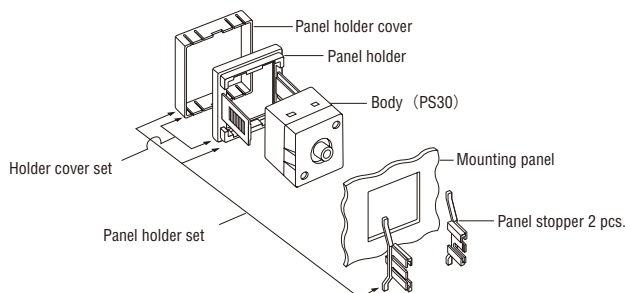

Name	Description	Contents
ACPG-001	Rear panel bracket set	Rear panel bracket and M3 x 4 male screw (2 pcs.)
ACPG-002	Panel bracket set	Panel bracket and M3 x 4 male screw (2 pcs.)
ACPG-003	Panel holder set	Panel holder cover Panel holder Panel stopper (2 pcs.)
ACPG-004	Holder cover set (For protecting operating panel)	Panel holder cover Panel holder
ACPG-005	Port block	Port block "O" ring (P8) M3 x 10 Male screw 2 pcs. Seal screw 1 pc.