

# PA-930

## PRESSURE TRANSDUCERS WITH AMP.



### FEATURES

- Suitable for high temperature media (150 °C)
- Compact and light weight due to original heat insulation technology
- High corrosion resistant SUS 316L port and nickel alloy sensor module

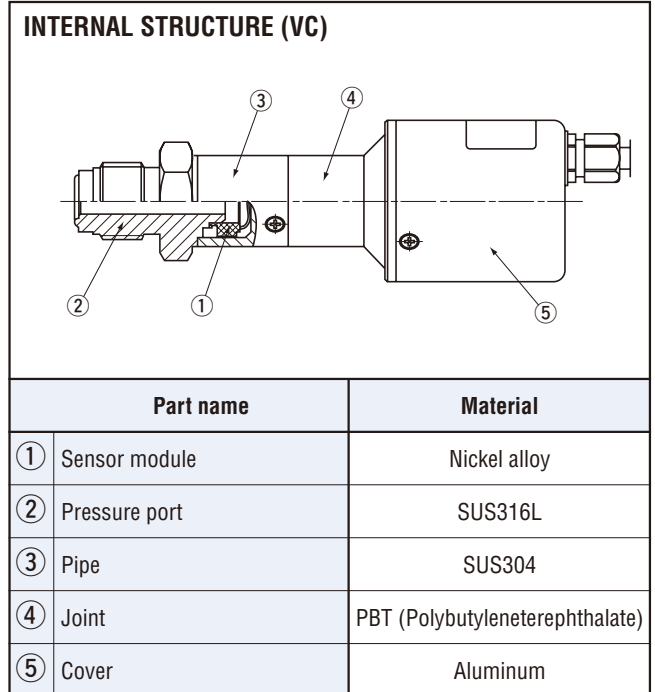

### MODEL NUMBER DESIGNATION

**PA-930-102R-VC**

Series name

Rated pressure range

- 102V : 0 ~ -100 kPa (Gauge-Vacuum)
- 102G : 0 ~ 100 kPa (Gauge)
- 102R : -100 ~ 100 kPa (Gauge-Compound)
- 103G : 0 ~ 1000 kPa (Gauge)
- 302R : -100 ~ 300 kPa (Gauge-Compound)

Pressure port

- VC : 9/16-18UNF
- R2 : R1/4 (PT1/4)

### LIST OF MODEL NUMBERS

Rated pressure range (kPa)	Pressure port	
	9/16-18UNF	R1/4 (PT1/4)
0 ~ -100	PA-930-102V-VC	PA-930-102V-R2
0 ~ 100	PA-930-102G-VC	PA-930-102G-R2
-100 ~ 100	PA-930-102R-VC	PA-930-102R-R2
-100 ~ 300	PA-930-302R-VC	PA-930-302R-R2
0 ~ 1000	PA-930-103G-VC	PA-930-103G-R2

※Verify the above model numbers when placing orders.

**PA-930**  
**PRESSURE TRANSDUCERS WITH AMP.**

**STANDARD SPECIFICATIONS**

● Unless otherwise specified, the specs are defined at a pressure port temperature of  $125 \pm 5$  °C and at an ambient temperature of  $25 \pm 5$  °C and excitation voltage of 24 V DC.

Item		Model number	PA-930				
			102V	102G	102R	302R	103G
General specifications	Pressure reference		Gauge				
	Rated pressure range	kPa	0 ~ - 100	0 ~ 100	- 100 ~ 100	- 100 ~ 300	0 ~ 1000
	Maximum pressure	kPa	200	200	200	600	2000
	Break-down pressure	kPa	300	300	300	900	3000
	Pressure medium		Corrosive gases/liquids compatible with SUS 316L and nickel alloy				
	Operating / Compensated	°C	0 ~ 50 (Circuit Board) 0 ~ 150 (Pressure port) /100 ~ 150 (Pressure port)				
	Operating humidity	%RH	35 ~ 85 (No condensation)				
	Storage temp.	°C	- 20 ~ 70 (Atmospheric pressure, humidity 65 %RH maximum)				
	Insulation resistance	MΩ minimum	50 (125 V DC)				
	Dielectric strength		125 V DC, 60 s (Leakage current 1 mA maximum)				
	Pressure port		9/16-18UNF, R1/4				
	Net weight	g	Approx. 100				
Power	Supply voltage	V DC	12 ~ 24 ± 10 %				
	Ripple content	maximum	10 % (P-P)				
	Consumption current	maximum	20 mA				
Analog output	Output voltage	V DC	1 ~ 5				
	Zero voltage	V ※1	1 ± 0.04	3 ± 0.04	2 ± 0.04	1 ± 0.04	
	Span voltage	V ※1	4 ± 0.04				
	Output current		1 mA max. (Load resistance 5 kΩ min.)				
	Linearity/Hysteresis	%F.S.	± 0.5				
	Thermal error	ZERO	± 0.10 %F.S./°C (100 to 150 °C, Reference temp. at 125 °C)				
		SPAN	± 0.10 %F.S./°C (100 to 150 °C, Reference temp. at 125 °C)				
Response		Approx. 2 ms.					

※1 : Pressure port temperature : 125 °C  
Ambient temperature : 25 °C

# PA-930 PRESSURE TRANSDUCERS WITH AMP.

## ENVIRONMENTAL CHARACTERISTICS

Test item	Test conditions (At 25 ± 5 °C)	Permissible change
Vibration	10 ~ 500 Hz, 1.5 mm maximum/98.1 m/s <sup>2</sup> , 3 directions for 2 hours each	Zero voltage, Span voltage: ± 1 %F.S. maximum each
Shock	490 m/s <sup>2</sup> , 3 directions for 3 times each	
Pressure cycling	0 ~ Rated pressure, 10 <sup>6</sup> cycles	
Moisture resistance	40 °C, 90 ~ 95 %RH, 240 hrs.	

## OUTLINE DIMENSIONS

Unless otherwise specified, tolerance : ± 0.5 (Unit: mm)

### VC type

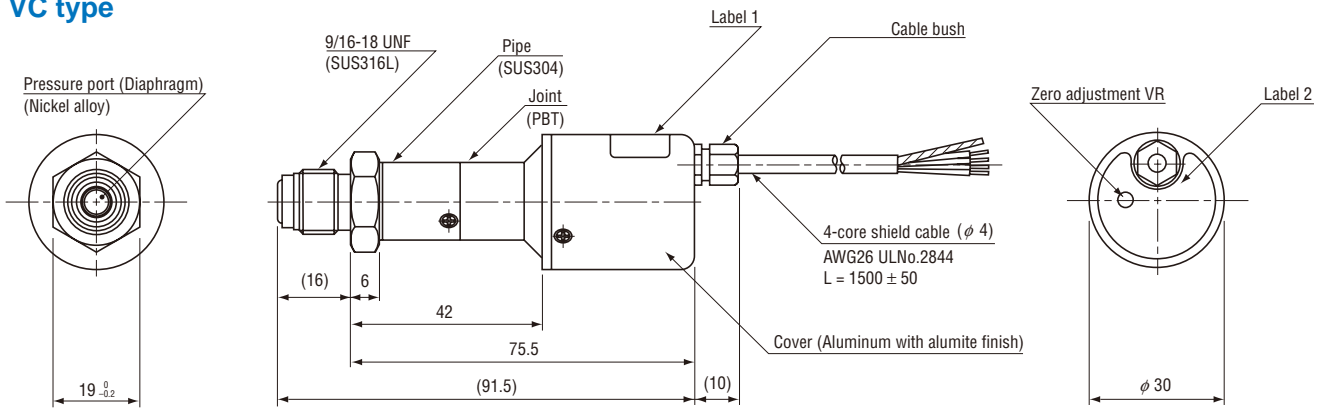

### R1/4 (PT1/4) type

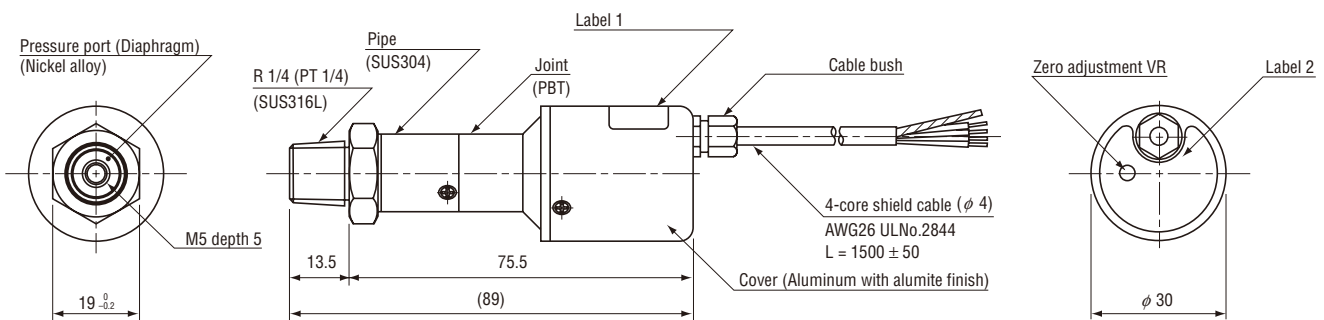

## INTERNAL ELECTRICAL SCHEMATICS

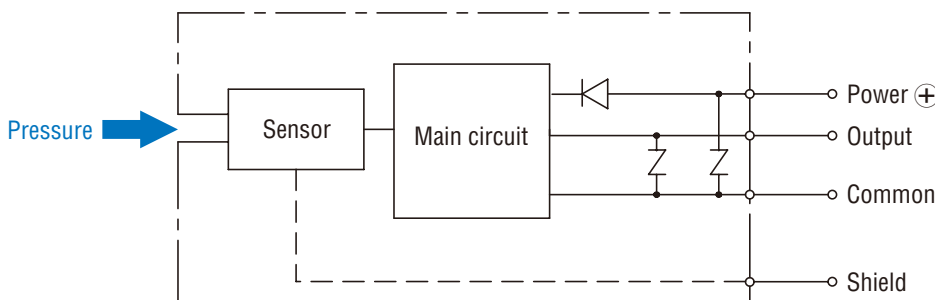

Wire color	Connection
Red	Power ⊕
White	Output
Black	Common
Green	N.C.
Shield	Fitting